

SymTech Laboratories Assembled MegaSquirt ECU's: Wiring Guide

MegaSquirt Installation Wiring Diagram Neon/420A Wasted Spark

Color code corresponds to the SymTech Labs Wiring Harness
Configuration corresponds to SymTech Labs' 420A-configured MegaSquirt ECU's
<http://store.symtechlabs.com/>

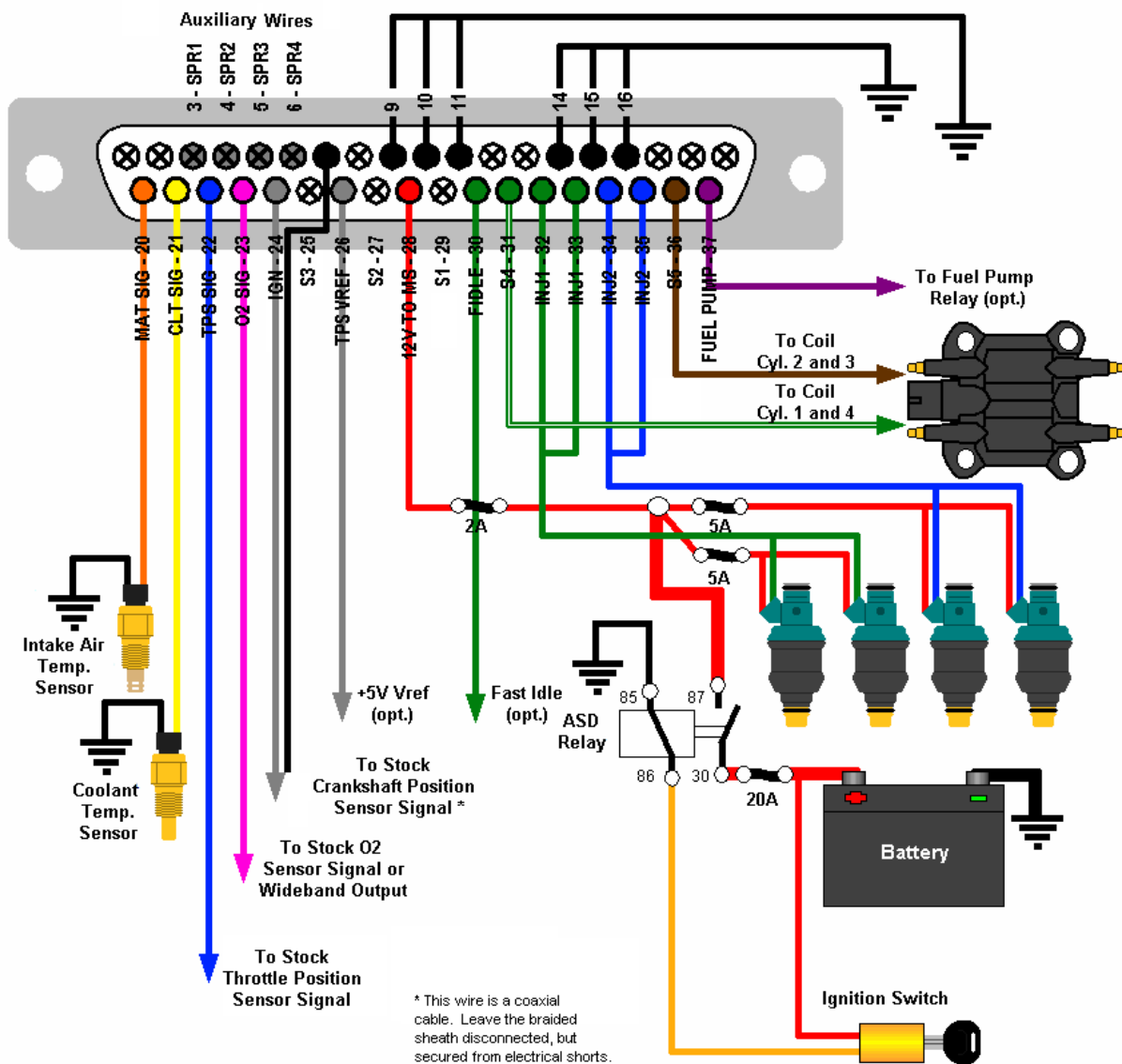

Need help? Contact support@symtechlabs.com anytime!